	INSTRUCTION MANUAL	classif: MUI 036 ing	pag. 1/21
	Jacketed valve on/off ANC DN 100-PN16 on/off 3WAY	rev. 1	data 23.05.2013

Instruction manual

Date 31st january 2002
 Written: Claudio Piotti
 Approved: Ing. Alberto Bassi

Le informazioni riportate in questo documento, sono confidenziali e di esclusiva proprietà della Società RIT S.r.l. , pertanto non sono ammesse copie e riproduzioni senza specifica autorizzazione scritta della Società RIT S.r.l.

This document and the information contained herein are confidential and exclusive property of RIT S.r.l. Unauthorized copying is strictly prohibited.

NOT CONTROLLED COPY

1	23.05.2013	9/21 - 11/21 – 12/21	Claudio Piotti	Ing. Alberto Bassi
0	31.01.2002	NO	Claudio Piotti	Ing. Alberto Bassi
REV	DATE	PAGE MODIFICATION	WRITTEN	APPROVED

	INSTRUCTION MANUAL	classif: MUI 036 ing	pag. 2/21
	Jacketed valve on/off ANC DN 100-PN16 on/off 3WAY	rev. 1	data 23.05.2013

INDEX

1.0 THE MANUAL'S SCOPE	pag. 04
2.0 SECURITY RULES	pag. 04
2.1. Warnings	pag. 04
2.2. Safety norm	pag. 05
3.0 CONFORMITY DECLARATION	pag. 06
4.0 GENERAL DESCRIPTION	pag. 07
4.1. Dimensions and weights	pag. 07
4.2. Identification plate	pag. 08
4.3. External control devices	pag. 08
4.4. Electrical connections	pag. 08
4.5. Pneumatic connections	pag. 08
4.6. Connections to heating jacket	pag. 08
5.0 OPERATION PRINCIPLE	pag. 09
6.0 INSTALLATION	pag. 09
7.0 START-UP	pag. 09
8.0 TROUBLE SHOOTING	pag. 10
9.1 The valve do not open	pag. 10
9.2 The valve do not close	pag. 10
9.3 The valve leaks	pag. 10
9.0 MAINTENANCE	pag. 10
9.1. Replacing the gasket of the body side 3 way	pag. 11
9.2. Replacing the packing	pag. 11
9.3. Replacing rod + plug assembly and basket cover side	pag. 12
9.4. Replacing the actuator gaskets.	pag. 13
9.5. Replacing micro switches	pag. 14
10.0 SPARE PARTS	pag. 14
10.1. Example of request	pag. 14
10.2. Recommended spare parts	pag. 14
11.0 AFTER SALE SERVICE	pag. 14
11.1. Request of technical intervention	pag. 14

	INSTRUCTION MANUAL	classif: MUI 036 ing	pag. 3/21
	Jacketed valve on/off ANC DN 100-PN16 on/off 3WAY	rev. 1	data 23.05.2013

12.0 PACKING AND SHIPMENT	pag. 15
13.0 STORING	pag. 15
14.0 DISMISSION	pag. 15
APPENDIX A: Materials' list	pag. 16
A.1 Material's list of valve type 07130 A	pag. 16
APPENDIX B: Drawings	pag. 17
B.1 dimensional	pag. 17
B.2 assembly valve type 07130 A	pag. 18
B.3 example of installation	pag. 19
B.4 diagram A pressure loss – flow rate	pag. 20
B.5 diagram B air pressure - differential pressure	pag. 21

	INSTRUCTION MANUAL	classif: MUI 036 ing	pag. 4/21
	Jacketed valve on/off ANC DN 100-PN16 on/off 3WAY	rev. 1	data 23.05.2013

1.0 THE MANUAL'S SCOPE

PRIOR TO INSTALLATION AND START-UP INSTRUCTION MANUAL AND SAFETY RULES HAVE TO BE READ AND OBSERVED.

The manual describe the functional and constructive characteristics of a 3-way valve on-off, with heating jacket, pneumatically actuated, spring return, called :

ANC DN 100 ON/OFF 3-way

We hope that this documentation will help the people in charge in ensuring trouble free and easy operation.

The ANC valve must be equipped with a solenoid valve for compressed air (max 12 bar) normally closed, with electrical supply to be stated according to the plant specifications.

2.0 SECURITY NORMS

2.1 WARNINGS

In the heating jacket of the valve, hot liquid, up to 280°C, is flowing to minimize any risk of burns due to these temperatures, the operators must wear suitable protective equipment, namely gloves with thermal protection.

The valve has been designed for assuring a suitable and reliable operation if installed in accordance with the manual's instructions.

For assuring the correct operation and suitable safety's levels, the installation, the survey and the maintenance must be exclusively carried out from qualified staff, in accordance with the manual's instructions.

Adaptations or modifications to the valve, if not approved by written from RIT S.r.l., should cancel the warranty.

Before executing every installation or maintenance operation not expressly described on this manual, please contact RIT S.r.l. that will give you the most wide co-operation for working out your problem, in order to not compromise the Security's System.

Each operator must respect, together with Manual's instructions, all the safety and installation rules valid on the installation's area and to the equipment's features.

	INSTRUCTION MANUAL	classif: MUI 036 ing	pag. 5/21
	Jacketed valve on/off ANC DN 100-PN16 on/off 3WAY	rev. 1	data 23.05.2013

2.2 SAFETY RULES

The installation, the operation, the maintenance and the repairs of the valve must be carried out only from authorized, learned and qualified staff.

- For executing the maintenance and the repair, use only suitable tools.
- Use only original spare parts.
- Before disassembling every components, shut off electrical supply.
- All the maintenance operations, ordinary supervision maintenance operations excepted, must be started only with the off duty unit, making sure that it can not be inadvertently started.
- Never use flammable solvents and ensure there is no risk of inhalation or skin contact with the cleaning substances being used.
- Keep the most scrupulous cleaning during the maintenance and repairing jobs. Protect from the soil pieces and the openings, covering them with cleaned cloth or sheets of paper.
- Not to execute weldings or grindings or other operations that generate heat on equipment under tension or in areas classified with explosion and fire hazard.
- Check that no tools, parts, cloth remains on transmission organs.
- Before carrying the start-up of the unit after the maintenance, every calibration and safety systems must be restored and correctly working.
- Wear always protective equipment (namely, glasses, gloves, helmet, footwear, etc.), as per local safety rules.

RIT S.r.l. do not accept any liability whatsoever for damage and/or consequential losses resulting from incompliance with these operating instructions.

	INSTRUCTION MANUAL	classif: MUI 036 ing	pag. 6/21
	Jacketed valve on/off ANC DN 100-PN16 on/off 3WAY	rev. 1	data 23.05.2013

3.0 CONFORMITY DECLARATION no. 0000-2014

Messers

**Subjet: Valve with heating jacket ANC DN 100 on/off 3WAY Type 07130 A
With lower limit switch**

YOUR ORDER N°0000
OUR REF.:N° NP0000
SERIES N°A014.000

CONFORMITY DECLARATION

With the present, the RIT S.r.l. places in *Via Volta 46*
20010 Mesero (MI) (Italy)
declares that:

The subject valves of the a.m. order are made in conformity to contract's qualifications and to the 97/23/CE Directive, according to the art's rule as per Art. 3, comma 3.

All the tests have been effected in accordance with the a.m. Directive and have had positive result.

MESERO, 07th JULY 2014

The Managing Director
A. Bassi

	INSTRUCTION MANUAL	classif: MUI 036 ing	pag. 7/21
	Jacketed valve on/off ANC DN 100-PN16 on/off 3WAY	rev. 1	data 23.05.2013

4.0 GENERAL DESCRIPTION

The equipment is suitable for liquids of groups 1 and 2.

The equipment does not perform safety functions.

These valves, pneumatically actuated AIR TO OPEN series ANC on/off with symmetric body and heating jacket, are particularly suitable for fluids having high viscosity at low temperature (bitumen, heavy oil, etc.), manufactured with DN 50-80-100 mm for diverting and regulating liquids of group 1 and 2.

The valves have 2 position and 3 ways, the fluid is diverted as follows:

- 1) **On line: valve not actuated (no air on the actuator), plug leaned against the seat of the 3rd way.**
- 2) **Towards the 3rd way: valve actuated (air on the actuator), plug leaned against the seat of the body.**

The main features:

- Fluid always running at working temperature. The pumps work at lower pressure without recirculation with possible overheating. Risk of hammer blow is avoided.
- Heating jacket from casting, not welded.
- Large symmetric openings on the body, allowing easy maintenance.
- Pneumatic piston actuator, compact and small, long life, more reliable in comparison with membrane one. On this actuator is possible, on request, to install position limit switches, with standard protection IP 65.
- The lower pressure of the control air is stated on the diagram at APPENDIX B.5.
- The piston, without gaskets, is manufactured in a special aluminium alloy corrosion resistant.

4.1 DIMENSIONS AND WEIGHTS

The dimensional drawing (APPENDIX B.1) shows the outline dimensions and relative weights.

	INSTRUCTION MANUAL	classif: MUI 036 ing	pag. 8/21
	Jacketed valve on/off ANC DN 100-PN16 on/off 3WAY	rev. 1	data 23.05.2013

4.2 IDENTIFICATION PLATE

It shows:

- Manufacturer's name;
- Series number;
- Manufacturing year;
- Min and max working and test pressure;
- Min and max working temperature.

4.3 EXTERNAL CONTROL'S DEVICES

The actuator is normally equipped with a 3 ways solenoid valve normally closed. The electrical supply is stated according to the plant characteristics, the control air is instrument air with 3 to 12 bar pressure.

4.4 ELECTRICAL CONNECTIONS

Must be performed only from qualified personnel, observing the usual rules and regulations related to the type of the plant and possible hazard classification. In any case, the prescriptions on the labels of solenoid valves must be strictly observed.

4.5 PNEUMATIC CONNECTIONS

A pressure reducer filter must be installed on the air net (instrument air max pressure 12 bar) in order to feed the solenoid valves with filtered air at constant pressure.

4.6 HEATING JACKET

The characteristics are:

- **Screwed connections dn:** **1 1/4" gas fem.**
- **Max pressure:** **12 bar**
- **Max allowed temperature:** **280°C**

The qualified personnel will connect the jacket accordingly to the a. m. characteristics and suitable for the heating fluid.

	INSTRUCTION MANUAL	classif: MUI 036 ing	pag. 9/21
	Jacketed valve on/off ANC DN 100-PN16 on/off 3WAY	rev. 1	data 23.05.2013

5.0 THE PRINCIPLE OF OPERATION

The valve is actuated with lubricated compressed air max 12 bar pressure, through a solenoid valve NC, passage diam. about 4mm.

Without control air (valve in position "0") the fluid is on line, because the piston plug Ref. 07.235/2 is leaned on the seat Ref. 07.235/1 of the 3rd way Ref. 07.234.

The valve is actuated by energizing the solenoid valve, feeding, through the hole "Z", the inferior chamber of the actuator. The piston Ref. 07.268/3 is pushed in position "1" and the piston plug leans on the seat of the body Ref. 07.235/1, diverting the flow on the 3rd way.

De-energizing the solenoid valve, the air on the actuator is discharged and the spring Ref. 07.277/3 shift the piston plug on position "0".

6.0 INSTALLATION

It is important to avoid that the weight of the pipes is supported by the valve itself.

Make sure that the flow direction is according to the narrow on the drawing APPENDIX B.2. and control air pressure according to the diagram APPENDIX B.5.

For special application it is possible to mount a larger actuator.

The valve can be installed in every position, we do not recommend the vertical one with actuator on the bottom, in order to avoid that possible leakages from the stuffing box can damage it. (See drawing APPENDIX B.3.). If the valves are installed with actuator in horizontal position, in case of possible hammer blows or vibrations, it is recommendable to anchor the actuator itself with anti-vibration supports.

Rev1

7.0 START-UP

After the valve has been flanged to the pipe and electrically and pneumatically connected (see APPENDIX B.3.) perform:

- idling tests "opening" and "closing";
- filling of the plant at low pressure;
- Checking that no leakage occurs;
- Start-up of the plant.
- After to have heated the valve at the working temperature and, afterwards, at ambient temperature, check the torque of the screws A-07.240/23 and A-07.230/25 at the value of 140 Nm. Such operation must be done at every replacement of the gasket A-07.230/24

Rev1

	INSTRUCTION MANUAL	classif: MUI 036 ing	pag. 10/21
	Jacketed valve on/off ANC DN 100-PN16 on/off 3WAY	rev. 1	data 23.05.2013

8.0 TROUBLE SHOOTING

8.1 the valve do not open

Check that the control air pressure is in accordance with diagram at the APPENDIX B.5.

8.2 the valve do not close

Check the loading of the spring Ref. 07.277/3

8.3 the valve leaks

The leakages can occur on the following positions:

- From the stuffing box if not correctly locked;
- From the gaskets body-bonnet and/or 3rd way: the gaskets must be replaced (APPENDIX A.1.), after a proper cleaning of the surfaces;
- From the actuator: replace the relevant gaskets;
- From the piston plug and seat: one of them or both are damaged by impurities on the product or on the pipes.

9.0 MAINTENANCE

The maintenance must be performed by trained and authorized staff only.

Any maintenance work, excepted the normal checking, must be started only with the unit out of service, make sure that it can not be accidentally started.

The maintenance must be usually performed in the workshop; if not possible, put the plant out of operation.

Check daily that no leakages or malfunctioning occurs on the unit.

Periodically the gaskets of the actuator must be cleaned and lubricated.

	INSTRUCTION MANUAL	classif: MUI 036 ing	pag. 11/21
	Jacketed valve on/off ANC DN 100-PN16 on/off 3WAY	rev. 1	data 23.05.2013

9.1 Replacement of gasket between body and third way:

- 01) Lift the rod + plug assembly by supplying air to the “Z” port of the actuator;
- 02) Unloose the screws Ref. A-07.230./25 keeping the actuator supplied with air;
- 03) Remove the third way;
- 04) Clean carefully the faces of the body and 3rd.way;
- 05) Check that the surfaces are not damaged;
- 06) Clean carefully the faces of the piston and seat;
- 07) Check that the surfaces are not damaged;
- 08) Fit the new gasket on the centering of the third way;
- 09) Join the third way to the body;
- 10) Tighten “crosswise” the screws Ref. A-07.230/25; with torque 140 Nm
- 11) Release rod + plug assembly disconnecting air to the actuator.

Rev1

9.2 Replacement of packing:

- 01) Make sure that the valve is not in operation;
- 02) Unloose fully the stuffing box Ref. 07.270/3;
- 03) Lift an end of packing Ref. A-07.230/07 by a medium screw driver;
- 04) Remove the ring with a pliers;
- 05) Repeat the operation until all the rings have been removed (approx. 6-8);
- 06) Lift the rod + plug assembly by supplying air to the “Z” port of the actuator;
- 07) Keep the actuator supplied and clean the part of rod between the bonnet and the spring ring nut;
- 08) Clean the stuffing box and the packing seat;
- 10) Place the new packing fitting a ring at a time;
- 11) Make sure to alternate at 180° the position of the end of the rings in order to avoid the overlap;
- 12) After fitting 3-4 rings tighten the stuffing box, in order to pack the rings on the bottom;
- 14) Unloose the stuffing box and fit the remaining rings;
- 15) Tighten the stuffing box without locking it;
- 16) Release rod + plug assembly disconnecting air to the actuator;
- 17) Adjust the stuffing box when the valve is in operation.

	INSTRUCTION MANUAL	classif: MUI 036 ing	pag. 12/21
	Jacketed valve on/off ANC DN 100-PN16 on/off 3WAY	rev. 1	data 23.05.2013

9.3 Replacement of body gasket, or rod + plug assembly:

- 01) Lift the rod + plug assembly by supplying air to the “Z” port of the actuator;
- 02) Unloose the screws Ref. A-07.230/25 keeping the actuator supplied with air;
- 03) Remove third way Ref. 07.234;
- 04) Release rod + plug assembly disconnecting air to the actuator;
- 05) Unloose the spring ring nut Ref. 07.269/23, in order to reduce the spring's load;
- 06) Unloose the stuffing box Ref. 07.270/3;
- 07) Remove the pin Ref. 07.230/22 joining rod + plug assembly Ref. 07.235/1 +
- 08) Ref. 07.235/2 to the stem Ref. 07.261/3;
- 09) Block the stem with a spanner and by another one unloose rod + plug assembly;
- 10) Extract rod + plug assembly from the bonnet Ref. 07.232;
- 11) Unloose the screws Ref. A-07.230/23;
- 12) Lift and extract the actuator from the valve;
- 13) Join the actuator on the working table, paying attention not to damage it;
- 14) Clean carefully the components and the faces;
- 15) Check and, if necessary, replace rod + plug assembly, seat ring Ref. 07.235/1,
- 16) packing Ref. 07.230/07 and gasket Ref. 07.230/24;
- 17) Replace the damaged elements with original spares;
- 18) Clean carefully the body Ref. 07.231/A and the bonnet faces;
- 19) Fit the new gasket on the centering of the bonnet;
- 20) Put the actuator on the body valve;
- 21) Make sure that gasket remains in the correct position and flow direction is
- 22) according to drawing;
- 23) Tighten “crosswise” the screws Ref. A-07.230/23 with torque 140 Nm Rev1
- 24) Fit the rod + plug assembly on the bonnet;
- 25) Lock the stem by a spanner and by another one unloose rod + plug assembly;
- 26) Join with a spin rod + plug assembly to the stem;
- 27) Lift the rod + plug assembly by supplying air to the “Z” port of the actuator;
- 28) Fit the new gasket on the centering of the third way;
- 29) Put the third way on the body;
- 30) Make sure that the gasket remains in correct position;
- 31) Tighten crosswise the screws Ref. A-07.230/25; with torque 140 Nm Rev1
- 32) Loose the spring ring nut, in order to regulate the spring's compression;
- 33) Loose the stuffing box;
- 34) Release rod + plug assembly and actuate the valve several times, in order to
- 35) be sure that no friction occurs;

	INSTRUCTION MANUAL	classif: MUI 036 ing	pag. 13/21
	Jacketed valve on/off ANC DN 100-PN16 on/off 3WAY	rev. 1	data 23.05.2013

9.4 Replacement of actuator's gasket:

Warning: on the actuator is installed *A PRELOADED SPRING DANGEROUS FOR THE OPERATOR* if the following instructions are not strictly observed.

- 01) Put the valve on the table in convenient position;
- 02) Unloose the nuts Ref. A-07.230/02 of cylinder tie-rod Ref. 07.265/3 unlocking the cylinder Ref. 07.266/3;
- 03) Remove the upper cylinder cap Ref. 07.2009;
- 04) Remove the cylinder Ref. 07.266/3;
- 05) Unloose the spring ring nut Ref. 07.269/23 in order to reduce the spring's load Ref. 07.277/3;
- 06) Lock the stem Ref. 07.261/3 with a spanner;
- 07) Unloose the self-locking nut Ref. A-07.230/26;
- 08) Remove the self-locking nut, the washer Ref. A-07.230/05, the piston;
- 09) Unloose at the same time the screws Ref. A-07.230/06 locking the cylinder head Ref. 07.236 to columns Ref. 07.264/3;

WARNING! THE SPRING IS PRELOADED

- 10) Remove the cylinder head;
- 11) Clean carefully all the disassembled parts;
- 12) Check the gaskets Ref. A-07.230/04-17-19-20-21;
- 13) Remove the gaskets to be replaced with a medium screw driver;
- 14) Clean carefully the gasket's seats;
- 15) Fit the new gaskets paying attention do not damage them;
- 16) Lubricate the gaskets with suitable grease;
- 17) Fit the cylinder head on the stem paying attention not to damage the gaskets;
- 18) Paying ATTENTION to the position of the "Z" feeding port: it must be upstream;
- 19) Loose slightly both the screws Ref. A-07.230/06 fitted with washers Ref. A-07.230/05
- 20) Make sure that the cylinder head is in correct position, then loose the screws Ref. A-07.230/06;
- 21) Fit the O-ring on the stem Ref. A-07.230/19;
- 22) Fit the piston, with O-ring seat down, the washer and loose the self-locking nut;
- 23) Lock the stem with a spanner;
- 24) Loose the self-locking nut;
- 25) Fit the cylinder;
- 26) Fit the cap Ref. 07.2009 with the "Y" hole upstream;
- 27) Fit the cylinder tie-rod loosening the nuts;
- 28) Tighten "crosswise" the nuts;
- 29) Supply and discharge air of actuator through the "Z" port;
- 30) Make sure that there are not air leakage from actuator;
- 31) Make sure that the valve opens and closes correctly without friction.

	INSTRUCTION MANUAL	classif: MUI 036 ing	pag. 14/21
	Jacketed valve on/off ANC DN 100-PN16 on/off 3WAY	rev. 1	data 23.05.2013

9.5 ACCESSORIES: POSITION MICRO-SWITCH

Replacement of upper and lower micro-switch:

- 01) Make sure that the valve is not in operation;
- 02) Make sure that the micro-switch is not electrically connected;
- 03) Lock the switch with your hands;
- 04) Unscrew switch's body with a spanner;
- 05) Use only the original spares;
- 06) Join the spring on the switch's button;
- 07) Loose the switch on the body;
- 08) Restore the electrical connections;
- 09) Supply and discharge air of actuator through the "Z" port;
- 10) Make sure that, actuating the valve, the switch works correctly;
- 11) Make sure that there are not air leakage from the actuator;
- 12) Make sure that the valve opens and closes without friction.

10.0 SPARES

The correct operation and adequate safety levels are guaranteed only using original spare parts, tested and released by us.

RIT do not accept any warranty claim whatsoever for defects produced by the use of spare parts and/or accessories not supplied by us

10.1 EXAMPLE OF ENQUERY

With the enquiry please furnish the following data:

- a) Series number of the valve. "" N° SERIE: A014.00 "";
- b) Reference of the part. "" body gasket ref. 07.230/24 "".

10.2 RECOMMENDED SPARE PARTS

For the start-up and operation, we recommend:

- n° 1 complete set of gasket;
- n° 1 plug rod + plug ref. 07.260/3+07.235/2;
- n° 1 seat ref. 07.235/1.

11.0 AFTER-SALE SERVICE

RIT S.r.l. is ready to offer intervention for ordinary and extraordinary maintenance on site or in his own workshop, according to the specific requirements.

11.1 Request for technical intervention:

Pls contact RIT S.r.l, Via A.Volta, 46, Mesero – MI –
tel. 02-97285378, fax 02-97285344, E-mail: info@rit.it
and specify:

- Type and model of valve;
- The actual malfunctioning;
- Manufacturing year;
- Series number.

	INSTRUCTION MANUAL	classif: MUI 036 ing	pag. 15/21
	Jacketed valve on/off ANC DN 100-PN16 on/off 3WAY	rev. 1	data 23.05.2013

12.0 PACKING AND DELIVERY

The standard packing is Euro pallet dim. 80 x 120 cm with the valves properly protected and fastened.

On receipt of the goods, pls. check that:

- The packing is not damaged;
- The goods are in accordance with delivery note;
- **note:** when not mentioned on the order, the transport is at care and expenses of the customer. Any damage due to transport and/or missing parts have to be reported in writing without any delay.

13.0 STORING

Warranty will not be applicable to any damage due to storing without protection from:

- weather;
- temperatures higher than +65°C;
- temperatures lower than -10 °C;
- saline ambient;
- aggressive ambient with solvents, mercury, soda etc.

14.0 DISPOSAL

Disposal of the valve will be made in accordance to the local valid rules.

	INSTRUCTION MANUAL	classif: MUI 036 ing	pag. 16/21
	Jacketed valve on/off ANC DN 100-PN16 on/off 3WAY	rev. 1	data 23.05.2013

APPENDIX A

A.1. MATERIALS' LIST VALVE ANC Dn. 100 on/off 3way type 07130 A

Code	Description	Material
A-07.230/02	Nut	8.8
A-07.230/03	Washer	8.8
A-07.230/04	Gasket	Flexoil.
A-07.230/05	Bonded washer	Sint.
A-07.230/06	Screw	8.8
A-07.230/07	Packing	Lub s
A-07.230/08	Spring pin	Spec. Carbon Steel
A-07.230/13	Filter	Brass
A-07.230/17	OR gasket	NBR
A-07.230/19	OR gasket	NBR
A-07.230/20	DI gasket	NBR
A-07.230/21	Dust cover	NBR
A-07.230/22	Spring pin	Spec. Carbon Steel
A-07.230/23	Screw	8.8
A-07.230/24	Gasket	Klinger PDM 200 AS
A-07.230/25	Screw	8.8
A-07.230/26	Self-locking nut	8.8
07.231/A	Body	Spheroidal Cast Iron GS400
07.232	Cover	Spheroidal Cast Iron GS400
07.234	Third way	Spheroidal Cast Iron GS400
07.235/1	Seat ring	AISI 304
07.235/2	3-way plug	Aluminium
07.236	Cylinder head	Cast Iron G25
07.2009	On-off cap	Cast Iron G25
07.260/3	Plug rod	Carbon Steel
07.261/3	Stem	Carbon Steel
07.264/3	Column	Carbon Steel
07.265/3	Cylinder tie-rod	Carbon Steel
07.266/3	Cylinder	Chromium Steel
07.268/3	Piston	Aluminium
07.269/13	Spring disc	Carbon Steel
07.269/23	Spring ring nut	Carbon Steel
07.270/3	Stuffing box	Brass
07.272	Bearing	Bronze
07.277/3	Spring plug	Spec. Carbon Steel

	INSTRUCTION MANUAL	classif: MUI 036 ing	pag. 17/21
	Jacketed valve on/off ANC DN 100-PN16 on/off 3WAY	rev. 1	data 23.05.2013

APPENDIX B

B.1. DIMENSIONAL VALVES ANC a 2 e 3 way type ON/OFF and 2A

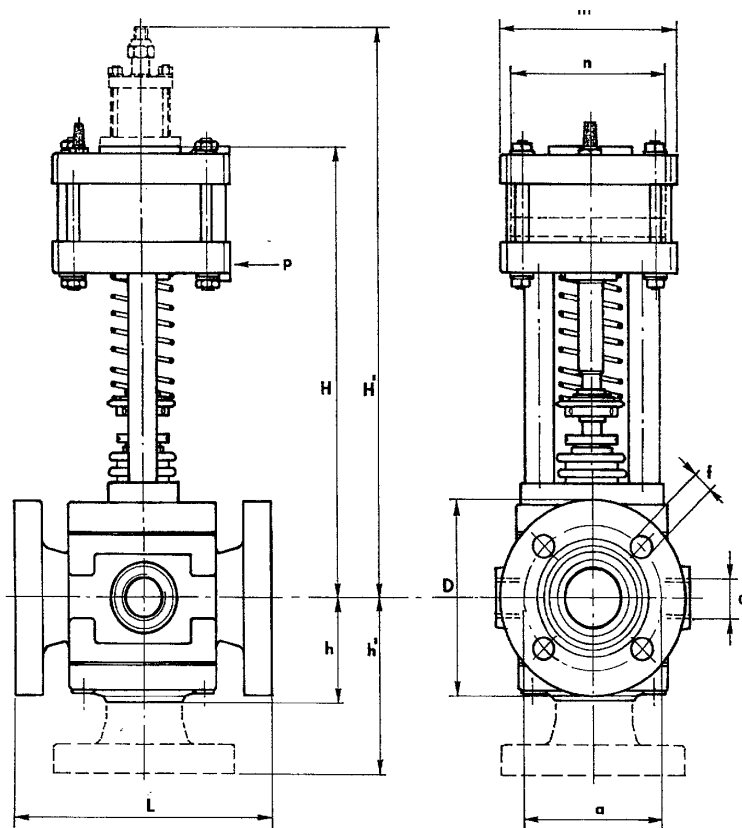

DIMENSIONS

Dn mm	Size inch	n	m	p	H	H'	h	h'	L	D	a	f	d
50	2	100	124	¼ Gas	345	445	84	150	230	165	125	18 x 4	1" Gas
80	3	125	154	¼ Gas	440	560	118	180	310	200	160	18 x 8	1" Gas
100	4	150	180	¼ Gas	490	635	133	200	350	220	180	18 x 8	1 ¼" Gas

WEIGHTS

Dn	Size	On/off 2vie	On/off 3 vie	2 a 2 vie	2 a 3 vie
50	2"	Kg.33	Kg.36	Kg.34	Kg.37
80	3"	Kg.49	Kg.54	Kg.50	Kg.55
100	4"	Kg.58	Kg.68	Kg.60	Kg.70

	INSTRUCTION MANUAL	classif: MUI 036 ing	pag. 18/21
	Jacketed valve on/off ANC DN 100-PN16 on/off 3WAY	rev. 1	data 23.05.2013

B.2. ASSEMBLY VALVE ANC Dn. 100 on/off 3way type. 07130 A

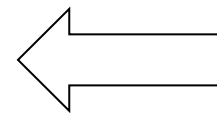
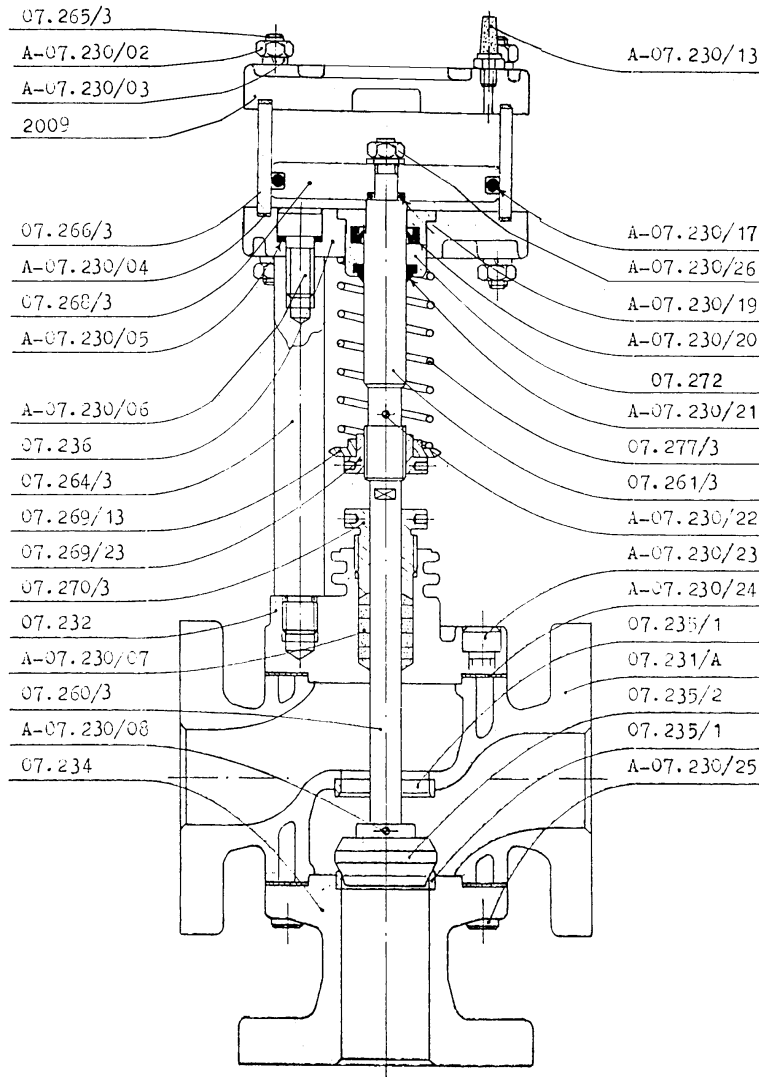

FLOW DIRECTION

	INSTRUCTION MANUAL	classif: MUI 036 ing	pag. 19/21
	Jacketed valve on/off ANC DN 100-PN16 on/off 3WAY	rev. 1	data 23.05.2013

B.3. EXAMPLE OF INSTALLATION

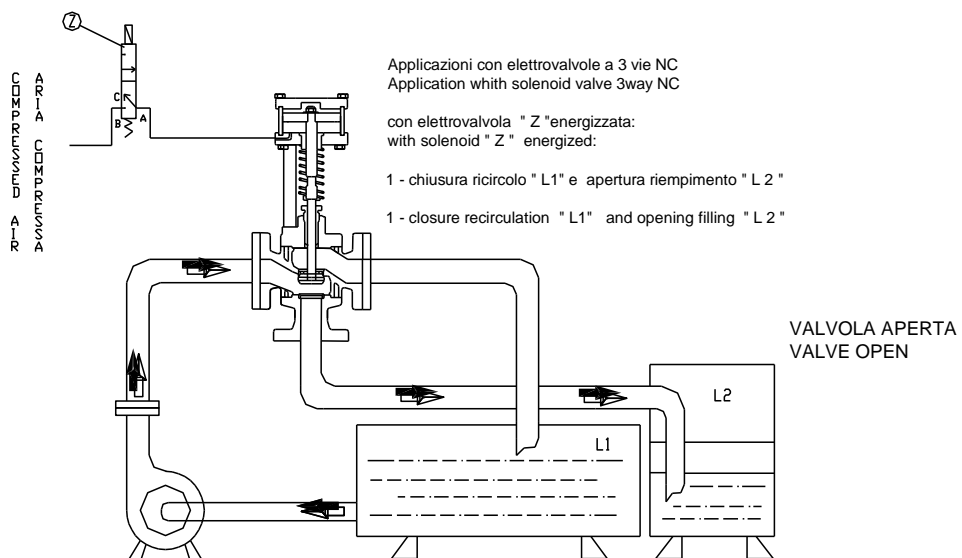
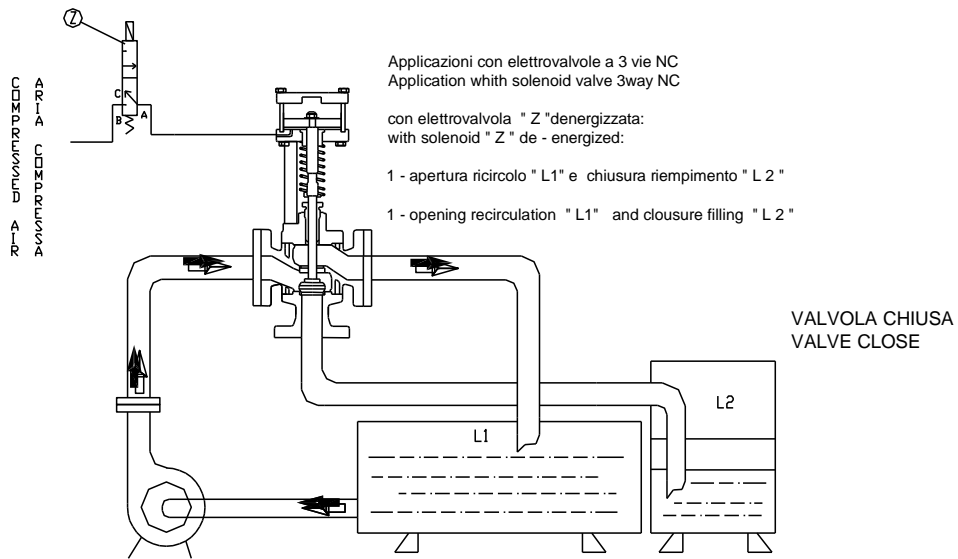

	INSTRUCTION MANUAL	classif: MUI 036 ing	pag. 20/21
	Jacketed valve on/off ANC DN 100-PN16 on/off 3WAY	rev. 1	data 23.05.2013

B.4. DIAGRAM A: PRESSURE LOSS FOR VALVES
 ANC a 2 e 3 way type ON/OFF and 2A

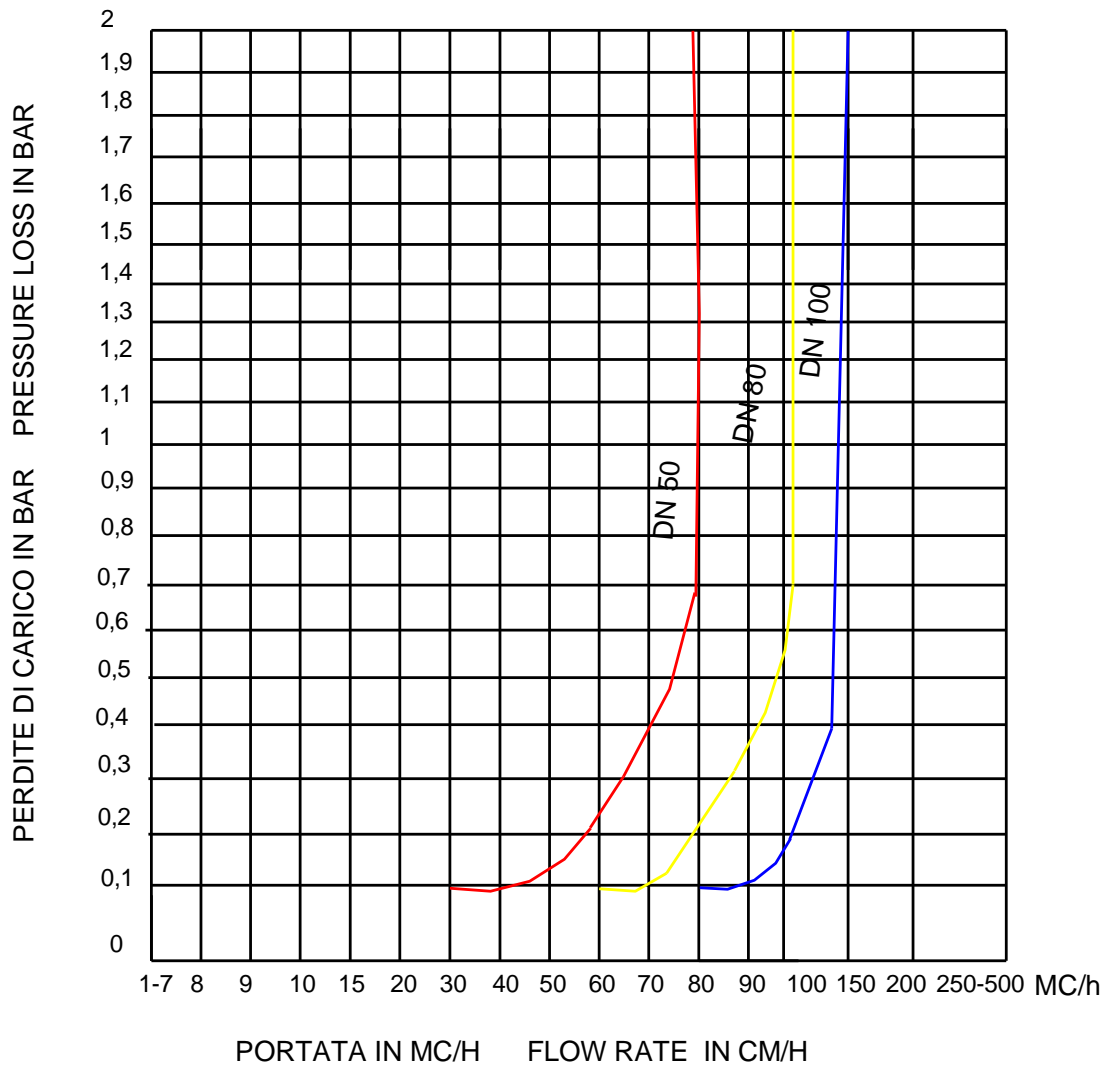

	INSTRUCTION MANUAL	classif: MUI 036 ing	pag. 21/21
	Jacketed valve on/off ANC DN 100-PN16 on/off 3WAY	rev. 1	data 23.05.2013

B.5. DIAGRAM. B: PRESSURE OF CONTROL AIR/DIFFERENTIAL PRESSURE
 For valves ANC a 2 e 3 way type ON/OFF and 2A

diagram B

